

Specifications for
BITUMINOUS JOINT SAWING & SEALING

The Town of Rice Lake will be accepting bid proposals for a Contractor to saw and seal joints in local streets. The intent of this contract is to ensure the Town of Rice Lake that sawing and hot rubberized cracksealing of all cracks shall be accomplished in a responsible and timely manner.

The work shall consist of saw cutting, cleaning, drying and sealing transverse joints in new bituminous surfaces according to the following specifications:

EQUIPMENT:

1. **General:** Equipment, vehicles and tools necessary for heating, cleaning, unloading, transporting and applying materials and for performing and maintaining all parts of the work, satisfactory as to design, capacity and mechanical conditions for the purpose intended, must be maintained in full working order, or which is used by the contractor is proven inadequate to obtain results prescribed, shall be repaired, improved, replaced or supplemented to obtain the progress and workmanship contemplated by the contract. In the event the equipment furnished and used is inadequate or unsatisfactory to obtain the progress and workmanship contemplated, operations shall be suspended until such conditions have been rectified. All equipment, vehicles and tools necessary for this contract, listed or otherwise, shall be considered a part of this subsection.

2. **Equipment:** The melting kettle shall be double jacketed boiler type, equipped with both agitation and recirculation systems capable of melting and applying the sealant through a pressure-fed hose and wand. The melter shall be capable of starting at ambient temperature and bringing the sealing material to application temperature in one hour or less, while continuously agitating and recirculating the sealant. The meter shall be equipped with automatic thermostatic controls and temperature gauges to monitor the sealant temperature in the applicator lines and temperature of heat transfer oil in the kettle jacket.

A self-propelled power saw capable of providing a straight cut of uniform depth and width shall be used. Diamond saw blades with either single or gang blade arrangement shall be used. The saw blade or blades shall be of such size and configuration such that the desired joint reservoir shape and deep saw cut are achieved in one pass of the saw. Two pass cutting will not be allowed. No spacers between blades shall be allowed unless the Contractor can show that the desired reservoir and saw cut can be obtained with them. Either wet or dry sawing will be permitted provided the above conditions are met.

The air compressor shall be capable of producing a continuous stream of clean, dry air through the nozzle at 100 psi and 125 ft³/ minute (CFM) minimum. The compressed air unit shall be equipped with water and oil traps and must produce sufficient air volume and pressure to remove all debris from the sawed joint and all adjacent road surfaces in a safe manner such that the debris will not re-enter the joint prior to the sealing operation

The heat lance shall operate with propane and compressed air in combination and be capable of achieving a temperature of heated air at the exit orifice of 1,800°F and a discharge velocity of 3,000 ft/sec.

PREPARATION AND FILLING:

1. **General:** The Contractor shall conduct the operation so that saw cutting of transverse joints, cleaning, and sealing are a continuous operation. Traffic shall not be allowed to knead together or damage the sawed joints. Sawed joints not sealed before traffic is allowed on the pavement shall be re-sawed, if necessary, when sawing and sealing operations resume at no additional cost to the Owner. Saw cutting, cleaning and sealing shall not be done within 48 hours of placement of the wear course.

2. **Saw cutting of Transverse Joints:** The transverse saw cut joints shall normally extend the full width of the pavement and shall extend into the asphalt shoulder or to the adjacent curb & gutter line, unless otherwise directed by Town Chairperson or duly authorized person(s). The transverse saw cut joints shall be spaced at 40 feet intervals or closer if requested.

3. **Cleaning Operation:** Dry sawed joints shall be thoroughly cleaned with an air compressor meeting the requirements previously outlined. Cleaning shall continue until the joint is dry and all dirt, dust or deleterious matter is removed from the joint and adjacent pavement to the satisfaction of the Town Chairperson or duly authorized person(s).

Wet sawed joints and adjacent pavement shall be thoroughly cleaned with a water blast (50 psi minimum) immediately after sawing to remove any sawing slurry, dirt or deleterious matter adhering to

the joint walls or remaining in the joint cavity. The joints shall then be dried with an air compressor. Cleaning shall continue until the joint is dry and all dirt, dust or deleterious matter is removed. If the air compressor produces dirt or other residue from the joint cavity, the Contractor may be required to re-clean the joint with a water blast.

Following cleaning, the sawed joints shall be dried and warmed with a hot air lance. The Contractor shall be careful not to burn the pavement surface.

4. **Sealing Operation:** The joints shall be sealed when the sealant material is at the pouring temperature recommended by the manufacturer. The Contractor shall fill the joint such that after cooling, the sealant is flush with the adjacent pavement along the edges and the center does not sag more than 1/8 inch below the pavement or shoulder surface. Care shall be taken in the sealing of the joints so that the joints are not overfilled and the final appearance shall present a neat fine line.

The Town Chairperson or duly authorized person(s) may require the Contractor to use a squeegee to force the sealant material into narrow joint shapes if, in the Owners opinion, the sealant material is not flowing into the joint properly. Sand shall not be spread on the sealed joints to allow for opening to traffic. The sealant shall be tack free before opening to traffic.

MATERIAL:

1. **Joint Sealant Material:** The Contractor shall provide certification that the sealant meets the requirements of ASTM D-3405 with the following modifications:

Penetration at 77°F 90 – 150

Bond at -20°F, Std. Specimen, 3 cycles, 200% extension Passes

The sealant material shall weigh not less than 9.00 nor more than 9.35 lbs/gallon.

Mixing of different manufacturers' brands or different types of sealants shall be prohibited. A certificate of compliance shall be furnished to the Town Chairperson or duly authorized person(s), upon request

WEATHER LIMITATIONS:

1. Sealant materials may be placed during a period of rising temperature after the air temperature in the shade and away from artificial heat sources has reached 40°F and indications are for a continued rise in temperature. During a period of falling temperature, placement of the sealant material shall be suspended until the above conditions are met.

TRAFFIC CONTROL:

1. **Traffic Routing:** Traffic shall be rerouted as deemed necessary allowing that all operations shall be so conducted as to provide a minimum of inconvenience to traffic.
2. **Barricades:** Barricades and signing necessary for the protection of the general public shall be used and shall be the responsibility of the Contractor.
3. **Notification:** Written notification shall be given to Police, Fire and Street Departments of the municipality at least twenty-four (24) hours prior to closing off or in any way effecting through vehicular traffic on any street.
4. **Curing and Protection:** The Contractor shall erect and maintain suitable barricades and/or cones and employ such watchmen as may be necessary to exclude traffic from the newly sealed areas until thoroughly cured or set. Any part of the work damaged prior to acceptance of the project by the owner shall be repaired and/or replaced at the expense of the Contractor.

MAINTENANCE:

The Contractor shall be responsible for and maintain the work until acceptable thereof. Such maintenance shall include protection and repair of the treated surface. Any areas containing any excess or deficiency of bituminous material or any unsatisfactory areas in the sealing shall be corrected during such maintenance period.

METHOD OF MEASUREMENT:

The Owner shall have an onsite inspector on site at all times and will require daily reports. The Contractors shall provide the Owners Inspector with daily footage reports. Payment **per lineal foot** of saw & seal performed and approved shall be the basis for measurement.

BASIS FOR PAYMENT:

The saw & sealing of bituminous joints shall be paid for on a **per each lineal foot** of saw & seal furnished and installed. Payment shall be full compensation for all labor, equipment, materials, and incidentals required for the completion of this maintenance contract.

GENERAL:

1. Streets to be saw & sealed may vary and shall be set by the Town Chairperson or duly authorized person(s).
2. The Contractor shall not perform any extra work without authorization of the Town Chairperson.
3. Contractor shall proceed with contract within ten (10) working days from the time of notification from the Town Chairperson or duly authorized person(s).
4. Work shall be done no later than **September 15th** of the year bid. Failure to complete work by this date will result in a \$200 per day penalty being assessed until work is completed.
5. Late work hours shall have the approval of the Town Chairperson.
6. The Contractor shall have a qualified person or persons in charge of his operations.
7. The failure of the Town at any time to require performance by the Contractor of any provisions hereof shall in no way effect the right of the Town thereafter to enforce the same. Nor shall waiver by the Town of any breach of such provisions here of be taken or held to be a waiver of any succeeding breach of such provisions or as a waiver of any provision itself.
8. If any provision of the contract shall be declared illegal, void or unenforceable, the other provisions shall not be effected but shall remain in full force and effect.

LIABILITIES:

As a condition of acceptance by Town of any bid, bidder shall satisfy all outstanding liabilities, if any, owing to the Town of Rice Lake by bidder.

PAYMENT:

Payment for sawing & sealing shall be upon satisfactory completion and approval of the Town Chairperson or duly authorized person(s).

NONDISCRIMINATION CLAUSE:

Without limiting the generality of any of the provisions of this Agreement, CONTRACTOR, in its operations, and also as a part of the consideration hereof, shall maintain and operate its facility and provide its services in compliance with and pursuant to Title 49, Part 21, Code of Federal Regulations, nondiscrimination in federally-assisted programs of the Department of Transportation-Effectuation of Title VI of the Civil Rights Act of 1964, and as said Regulations may be amended; and shall not on the grounds of race, creed, color or national origin, physical limitation or disability, or on any other prohibited basis discriminate or permit discrimination against any person or group of persons in the manner whatsoever.

In addition, the CONTRACTOR covenants that it will undertake an affirmative action program as required by 14 CFR Part 152, Subpart E, to insure that no person shall on the grounds of race, creed, color, national origin, or sex be excluded from participating in any employment activities covered in 14 CFR Part 2152, Subpart E. The CONTRACTOR assures the TOWN that no person shall be excluded on these grounds from participating in or receiving the services or benefits of any program or activity covered by this Subpart. The CONTRACTOR assures that it will require that its covered suborganizations provide assurances to the CONTRACTOR that they similarly will undertake affirmative action programs and that they will require assurances from their suborganizations, as required by 14 CFR Part 152, Subpart E, to the same effect.

LIABILITY INSURANCE REQUIRED:

No Contract shall be issued until Contractor has furnished satisfactory proof of a liability insurance policy in full force and effect a public liability insurance policy in a company authorized to do business in the State of Wisconsin for his total operation in the amount of a One Million Dollar (\$1,000,000.00) complete liability umbrella policy covering injury, death or destruction of property of any person other than the Contractor. Cancellation or reduction of insurance shall automatically suspend this contract and no further work shall be done.

CONTRACT REVOCATION OR SUSPENSION:

The Town Chairperson or duly authorized person(s) may temporarily suspend this contract for any violation of these specifications for a period not exceeding three (3) days, or may revoke such contract after an opportunity for hearing before the Town Board upon ten (10) days personal notice to the Contractor.

Sealed Bids shall be received until **7:00 p.m., Monday, May 8, 2017** at the Town of Rice Lake Clerk's Office, 1830 Macauley Ave., Rice Lake, Wisconsin. Bids shall be opened at **7:00 p.m. on Monday, May 8, 2017.** at the Town Municipal Building, 1830 Macauley Ave., Rice Lake, WI 54868. **All bids must be on Town of Rice Lake Bid Proposal forms and are to include a completed Town of Rice Lake Drug & Safety Survey (pages 7 & 8 of this packet).**

The Town of Rice Lake reserves the right to reject any or all bids, to waive informalities and to accept the proposal deemed most advantageous to the Town of Rice Lake.

Attachment A:

Proposed Saw & Seal List

ON ROUTE (Ave/St Number)	AT ROUTE (Starting Point)	OFFSET (Ft or Miles)	TOWARD ROUTE (Ending Point)	OFFSET (Ft or Miles)	DISTANCE MILES	SURFACE WIDTH	INTERVAL BETWEEN CUTS
20 ½ St.	23 ½ Ave.		24 th Ave.		0.54	22 ft	40 ft
22 ¾ Ave.	20 ½ St.		20 ¾ St.		} 0.35	22 ft	40 ft
20 ¾ St.	22 ¾ Ave.		Cul-de-sac (end just past 2309 20 ¾ St.)	0.04 mi		22 ft	40 ft
TOTALS					0.89		

Saw & Seal Typical Section

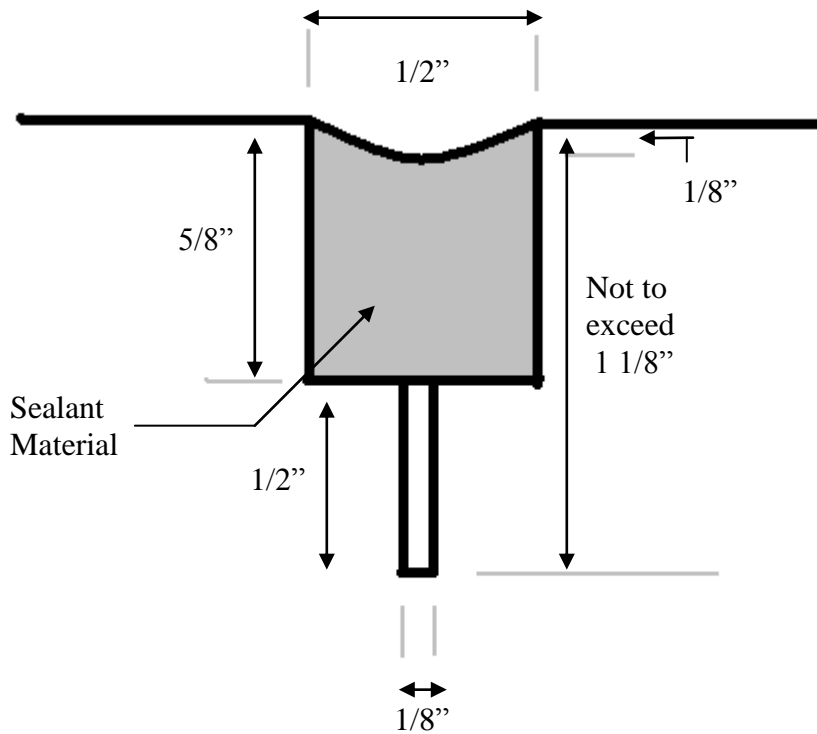

BID PROPOSAL

Proposal of _____

(hereinafter called "BIDDER"), organized and existing under the State of _____

doing business as _____ To the Town of Rice Lake, Wisconsin
(Hereinafter called "OWNER").

In compliance with your Advertisement for Bids, BIDDER hereby proposes to perform all work, clean and fill cracks in strict accordance with the Specifications, within the time set forth therein, and at the prices stated in the attached proposal form.

By submission of this BID, each BIDDER certifies as to its own organization, that this BID has been arrived at independently, without consultation, communications, or agreement as to any matter relating to this BID with any other BIDDER or with any competitor.

BIDDER agrees to perform all work described in Specification Documents for the following unit prices:

PROPOSAL FORM

Furnish and Install Saw & Seal Rubberized Filler

Bid #5: Saw & Seal bituminous joints per lineal foot at 40 foot intervals or closer if requested at
\$_____ per lineal foot.

Specify approximate starting date _____

In submitting this bid, it is understood that all work must be completed in accordance with the time schedule set forth in this proposal form, and the Town of Rice Lake reserves the right to reject any or all bids, to waive informalities, and to accept the bid proposal deemed most advantageous to the Town of Rice Lake.

It is agreed that this bid will not be withdrawn.

Upon the acceptance of this proposal, the successful Bidder shall be the Contractor and all references in the proposal to the Bidder shall apply to the Contractor for the year bid.

Respectfully submitted,

Contractor Signature _____

Printed Name _____

Title _____

Company Address _____

Phone Number _____

Email Address _____

Date _____

ACCEPTANCE OF PROPOSAL - The above prices, specifications and conditions are satisfactory and are hereby accepted. You are authorized to do the work as specified. Payment will be made as specified in the contract.

Date of acceptance: _____

Thomas Fankhauser, Chairman
Town of Rice Lake

Town Of Rice Lake

Barron County, Wisconsin

ATTENTION ALL CONTRACTORS SUBMITTING ROAD WORK BIDS:

The Town of Rice Lake now requires this form to be submitted with all road work bids to ensure that contractors are meeting industry standards.

Contractor _____ Phone _____

Address _____

1. Do you have a drug testing policy which includes *random* testing?

_____ NO

_____ YES Medical Review Officer: _____

Phone: _____

Consortium Management Group: _____

Phone: _____

2. Do you have Traffic Control / Flagger Training?

_____ NO

_____ YES Trainer: _____ Phone: _____

Most recent training date: ___/___/_____

3. Do you have a written Safety Program?

_____ NO

_____ YES *Please circle topics covered in the program*

Flagger Training

Traffic Control

Hazard Communication

Lockout / Tagout

Fire Protection

Personal Protective Equipment

Hearing Conservation

Drug Testing

Bloodborne Pathogen Awareness

Vehicle Inspection / Maintenance

Driver Logs

Respiratory Protection

4. Do you conduct Safety Meetings?

_____ NO

_____ YES Conducted by: _____ Phone: _____

How often: _____ Last date held: ___/___/_____

As an officer of the company, I verify the above is true and accurate.

Signature

Printed Name

Date

Title